

Alpha-Beta Particulates Monitor LB 150 D-R

RADIATION PROTECTION



ABPD Particulates Monitor combined with
Alpha Energy Range Discrimination (**AERD**)

Simultaneous Measurement of Artificial
Alpha- and Beta-Particulates with
highest sensitivity:
The **Fixed Filter Monitor LB 150 D-R**
with Compensation and Measurement of
Natural Radio Activity

Introduction

Application

The Alpha-Beta-particulates monitor LB 150 D-R can be deployed for the measurement of airborne artificial Alpha and Beta activity in

- ▶ Nuclear facilities in the Nuclear fuel cycle and Fission product production
- ▶ Storage and processing of Nuclear waste products
- ▶ Hot Cell Labs
- ▶ Monitoring of Alpha emitting (transuranic) substances

The Particulates Monitor LB 150 D-R uses a fixed filter and is a true real time Monitor while collection, detection and evaluation are done simultaneously.

Sampling

The very high sampling rate of 40 m³/h ensures a representative sampling for both Stack monitoring with Isokinetic extraction as well as Room or workplace air monitoring

Particulates collection and Detector

The sampled air is drawn through an S-class glass fiber filter with 200 mm Ø. The detector, a large surface proportional counter with thin entrance window, is located directly above the collection area at a distance of 7 mm and measures the radiation intensity from Alpha and Beta decays.

The airtight particulates collection unit can be constructed in Stainless steel or in Teflon depending on the application.

Air flow regulation

By means of a frequency regulator the sample air flow can be regulated proportional to a Stack flow or be kept constant i.e. independent of the dust loading on the filter.

- ▶ Proportional regulation (Optional):

This type of airflow regulation is used for Emission monitoring systems, specifically where strongly fluctuating exhaust or release flows are present, simultaneously the dust loading on the Filter is compensated for.

The Airflow through the monitor is regulated proportional to the Stack release flow. For this purpose a Stack flow rate (m³/h) proportional signal 0/4 – 20 mA has to be available.

- ▶ Constant flow regulation (Optional):

This operating mode can be used for all Applications. The sample airflow is regulated proportional to the filter dust loading. Therefore this mode is particularly suited for Room air monitoring or for Release Stacks without prefiltering (no HEPA filters).

To keep the air sample flow constant the air flow through the system is required. The flow rate information is obtained by means of a Vortex flow meter, which operates to the Karmann vortex principle, independent of pressure or temperature fluctuations. This flow measurement principle has no mechanical moving parts and is therefore almost maintenance free.

Alpha-Beta-Particulates Monitor LB 150 D-R

Electronics

The Analog electronics consists of the Preamplifier LB2015-31. The charge sensitive preamplifier/discriminator with Normed output pulses is located close to the Detector(s). Therefore it is possible to install the complete Collection unit at a distance up to 200 m from the Evaluation Electronics.

Evaluation Electronics

The versatile multi-counter Electronics LB9000 with 12" TFT touch screen Display and trackball keyboard is used as Data logger electronics. It serves as data processing and evaluation unit with ABPD/AERD application program for parameter entry and visualisation of the Measurement results. Eight different screens are available to present the measurements and graphics. They can show bar graphs with embedded thresholds for short, long, difference, sub integral and integral values as well as time based graphs with measured values.



Intelligent μ -controller modules with field proven CAN-Bus interface are used for front end signal processing and detector interfacing. Eleven slots for 5 different intelligent boards (modules) are available for measurement applications. Several identical modules can be used. In the basic version of the LB150DR monitor the LB9000 contains an ABPD module, a Multi I/O module and a power supply module. If additional inputs or outputs e.g. Analogue outputs are required simply adding extra modules allows for the extension. The LB9000 application software allows to perform Service & maintenance functions such as Plateau take-up, Background measurement, Efficiency calibration, automatic determination of Pseudo-coincidence factors, recurrent testing.

For data communication or print out of all relevant Measurement data and Parameters several interfaces are available. The data are kept in a FIFO data buffer of up to 10.000 results deep.

- ▶ 2 Password protected user levels
- ▶ FIFO Data buffer with 10000 results per Channel
- ▶ Optional Watchdog function with independent PLC unit
- ▶ Module communication via proven CAN-Bus technology
- ▶ Intelligent, self monitoring Modules with μ -Controllers
- ▶ Industrial-PC with 12,1" TFT-Monitor and Touch screen, CD-reader
- ▶ Relais board with 16 potential free Relais with dual changeover contacts
- ▶ Interfaces : 2xCOM, 1xParallel, 1xMouse, 1xKeyboard, 1xEthernet, 1 (2) xUSB

LB 9000 Modules in the LB 150 D-R

ABPD-Module LB 39415:

To measure and compensate for natural Activity consisting of ABPD-logic with Alpha gating and Beta delay line, coincidence gate with Alpha energy range discrimination (AERD) implemented in the Detector or Amplifier.

- ▶ Pseudo-coincidence board with α, β, γ -counter inputs
- ▶ 2 independent HV-Outputs (bis 4kV)

Multi I/O Module LB 39417-01:

4 Counter inputs, 2 Analogue inputs 0/4-20 mA/0-5V (1 x used for Sample air flow meter), 2 Analogue Outputs 0/4-20 mA, 4 digital inputs (3 x used for Status messages), 4 Control voltages 0-5V, 8 Open coll. Ouputs, Connection via Phoenix terminal block (48 pole)

Low Voltage module LB 39416: 4 x DIN connector socket +5V, +15V, -15V

8-fold Current output -Module (Optional): Linear- or logarithmic output, 8 independent analogue Outputs 0/4 – 20 mA

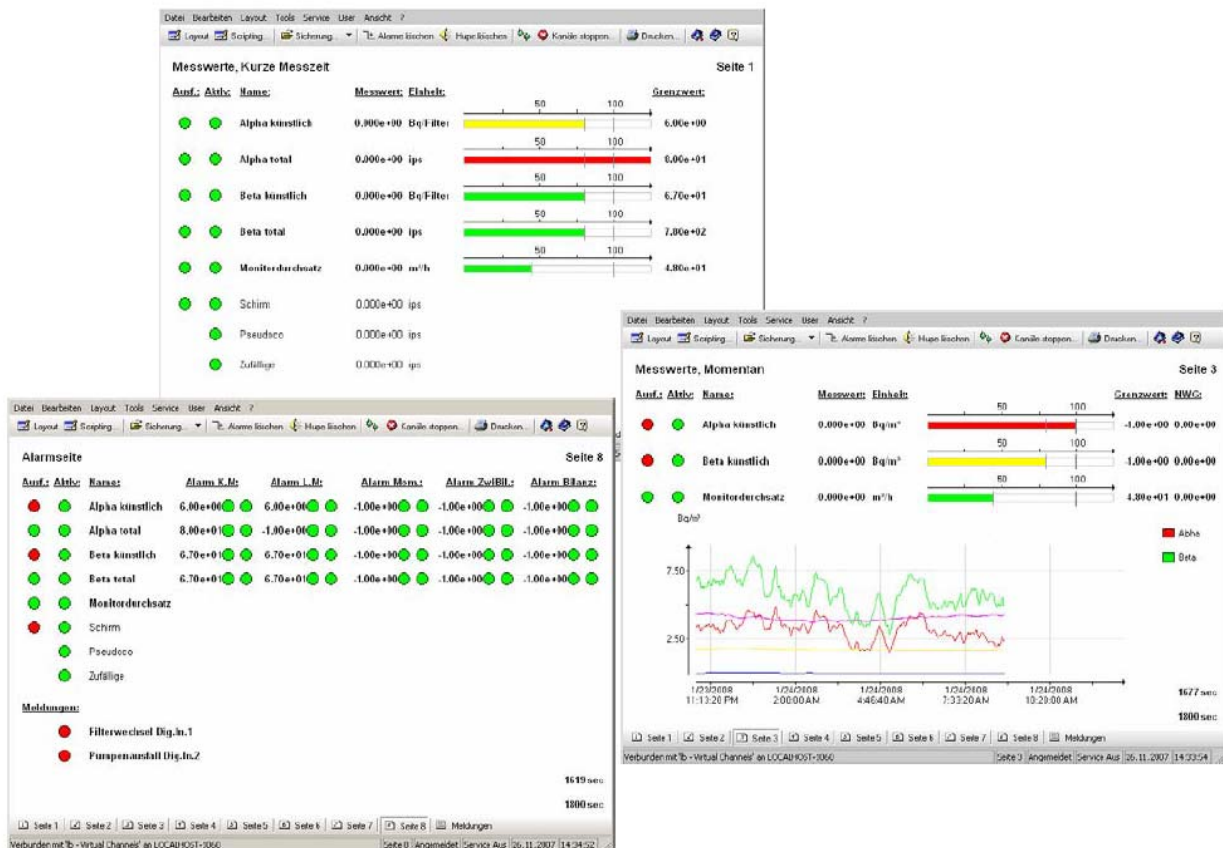

Measuring principles and methods

To detect small quantities of artificial radioactive particles in the presence of natural activity (Radon – Thoron daughters), which can have concentrations of 1 Bq/m³ up to several hundred Bq/m³ depending on Location, time of the Year, day or night and weather conditions (rain), a performant compensation mechanism against natural radioactivity is required.

To obtain such performing compensation against the natural radioactivity in the air sample, the Alpha Beta Pseudo-coincidence Difference method (ABPD) enhanced with Alpha Energy Range Discrimination (AERD) is used.

Alpha Beta Pseudo-coincidence Difference method

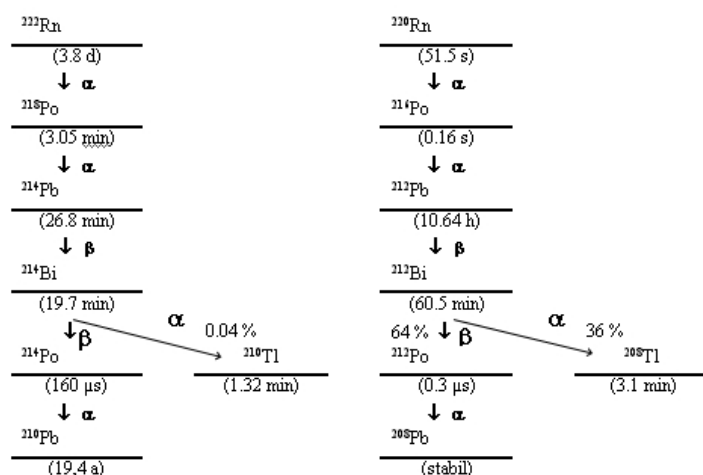

The ABPD method uses the specific measurement of the Bismut-214 decay into Polonium-214 and the Bismut-212 decay into Polonium-212 to compensate for natural activity.

Simplified we can say that the method is implemented in an electronics stage with a coincidence gate which is opened for a given time (>160μsec) as soon as a Beta decay is detected in the Detector. If during this gate time the Detector also ‘sees’ an Alpha

decay a pseudo-coincidence pulse is generated which is a measure for the natural activity in the sample. In practice the electronics uses the Alpha counts to trigger the gate, whereby the Beta’s are sent through a delay line. The reason for this is to obtain a wider dynamic range because in equilibrium the natural Alpha decays are about 1.6 times less than the natural Beta decays.

A good pseudo-coincidence stage should contain a second circuit to detect Random coincidences. These should be used to compensate the pseudo-coincidence stage for random coincidences at higher count rates to avoid overcompensation i.e. suppression of potential artificial radioactivity events. The ABPD module block diagram shown here has these 2 stages implemented the pseudo-coincidence stage (Bi-214/Po-214 and Bi-212/Po-212 decays) and the random (A/B) coincidence stage.

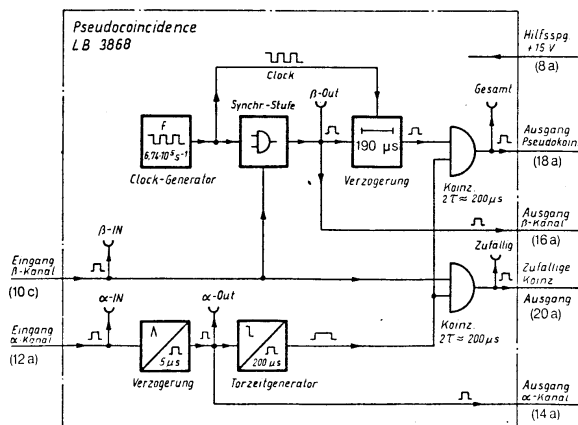

AERD Alpha Energy Range Discrimination

The AERD method uses a physical barrier to make an energy discrimination between high energy Alphas from natural isotopes and lower energy Alphas from artificial origin (up to 5,8 MeV).

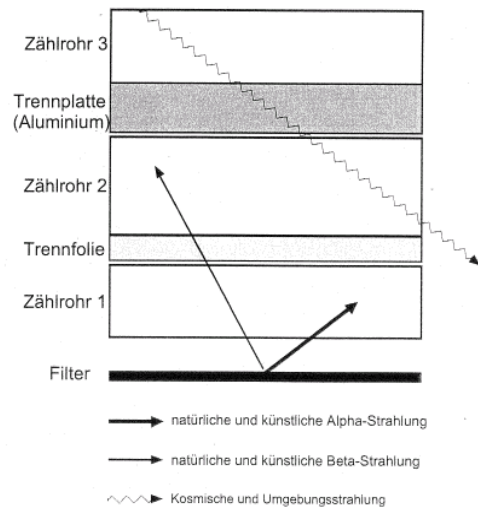

A high energy Alpha-particle will trigger an event in the two lower detectors ZR1 and ZR2 depicted here on the left.

Because both events occur quasi simultaneously these events can be eliminated with an Anti-coincidence gate.

This will eliminate the majority of natural Alpha's from the first detector ZR1 and only leave the artificial Alpha's.

An artificial Alpha-particle is prevented from entering the second detector ZR2 by absorption in the separating foil between the 2 detectors.

Therefore only the lower detector ZR1 will generate a pulse which is recorded as an artificial Alpha count.

Alpha-Beta-Particulates Monitor LB 150 D-R

Components of the Particulates Monitor LB150D-R

Multi-counter and processing Electronics LB9000

Alpha-/Beta-/Gamma-Detector GFDZ 200

- ▶ Simultaneous, separate detection of Alpha and Beta activities.
- ▶ Gamma-Detector to compensate fluctuating Gamma backgrounds

Particulates Collection Unit

- ▶ Isokinetic Air flow onto the Particulates filter
- ▶ 3-fold Detector with Preamplifier and pulse shaper
- ▶ 200 mm \varnothing Filter support sinter plate with drawer mechanism

Pump Unit with regulated Air flow

- ▶ Frequency regulated pumps ensure a constant Flow independent of filter loading (Option)
- ▶ Sample air flow Proportional to an external variable Release flow rate (Option)

19" Enclosure to mount all the Components



Status Monitoring Functions of the System

The system is equipped with self-monitoring functions for the critical operating parameters which will report any Alarm threshold breaching or failure condition.

- ▶ Monitoring of Pump function
- ▶ Monitoring of Filter Loading
- ▶ Monitoring of the Frequency Regulator unit
- ▶ Monitoring of the Collection Unit
- ▶ Monitoring for Detector failure of Alpha, Beta and Gamma detector
- ▶ Breaching of pre-Alarm thresholds
- ▶ Breaching of Alarm thresholds for Alpha and Beta

Interfaces

Depending on the Monitoring Application a number of interfaces is available : current outputs, analogue inputs, digital in- & outputs, printer and data communication interfaces as well as potential free change-over relay contacts.

- ▶ 16 freely selectable potential free Relays with dual change-over contacts
- ▶ 8 digital OC-outputs (optionally expandable to 16 or 24)
- ▶ 2 x RS 232
- ▶ 1 x Parallel
- ▶ 1 x USB
- ▶ 1 x Ethernet
- ▶ 2 x Current outputs 0/4 – 20 mA (optionally up to 20)
- ▶ 1 analogue input 0/4 – 20 mA or 0-5 V (optionally 3 or 5)
- ▶ optional 4 or 8 digital inputs

Key features of the LB150D-R Alpha- Beta Particulates Monitor

- ▶ **Simultaneous Measurement of Artificial Alpha- and Beta particulates**
- ▶ **Compensation and Measurement of Natural radioactivity (Rn/Tn daughters)**
- ▶ **3-fold Large surface proportional counter with high Alpha and Beta Efficiency**
- ▶ **Prompt Measurement of the activity deposited on the Collection Unit**
- ▶ **High Sample Air flow for representative sampling**
- ▶ **Collection of airborne particulates on a 200 mm Ø Glass fiber filter**
- ▶ **Continuous Measurement and Alarm Threshold monitoring during while sampling**
- ▶ **Isokinetic Air flow, known particulates loss factors taken into account**
- ▶ **Measuring principle independent of particulates Energy**
- ▶ **Independent of Pressure or Temperature fluctuations, minor influence of Filter loading**
- ▶ **Independent of Radon/Thoron ratio**
- ▶ **Minor influence equilibrium state of the Radon/Thoron progeny (depends on in situ conditions – Geological, Meteorological)**
- ▶ **Data collection and Evaluation Unit LB9000 with ABPD/AERD application program to set parameters and visualise Measurement results. Utility programs for service and maintenance : Calibration, Plateau take-up, Background measurement, recurrent testing, etc.**

Technical Data

Pump:	Silent Turbine pump Type SV 5.130/2 with max. 40 m ³ /h sample flow rate (Optional Type SV 5.90/2 with max. 30 m ³ /h sample flow rate)	
Filter disk:	Glas fiber filter, S-class Nr. 8, Schleicher & Schüll, Ø 200 mm or equivalent	
Ambient conditions:		
Ambient Temperature :	0 to 50 °C	
Sample Air Temperature:	up to 85°C	
Humidity:	max. 95 % rel. humidity	
Sample air pressure:	0.7 to 1.2 bar absolute	
Detector:		
Type:	3-fold Proportional counter tube GFDZ 200 in Sandwichconstruction	
Lead shield:	4 pi 2 cm (5 cm optional)	
Counting gas:	Methane, Natural Gas, Propane P10 or Ar-CO ₂ 90/10	
Gas consumption:	app. 2 l/h	
Backgrounds:	Alpha:	app. 0.2 cps
	Alpha/Beta:	app. 2.5 cps with Antico-Stage
	Guard:	appr. 6.0 cps
Measuring Range:	app. 200000 cps with Antico-stage Effectiveness ABPD/AERD-compensation up to approx. 500 Bq/Filter, beyond this integral Alpha- and Beta measurement up to 5 E+5 Bq/Filter	
Efficiencies:		
Alpha:	Am-241	23 % (Cal. Factor kf = 4.4 Bq/cps)
	U _{nat} :	16 % (Cal. Factor kf = 6.3 Bq/cps)
Beta:	Sr-90+	21 % (Cal. Factor kf = 4.8 Bq/cps)
	U _{nat} :	11 % (Cal. Factor kf = 9.1 Bq/cps)
	Co-60	11 % (Cal. Factor kf = 9.1 Bq/cps)
	(Measured with 200 mm Ø flat surface emission sources)	

Noble Gas influence:

Kr-85	24.8 kBq/m ³ /cps
Xe-133	69.0 kBq/m ³ /cps

(Data from KFA-Jülich, Germany)

Particulates Losses

Collection Unit:	Particle diameter in µm:	Loss in %:
	2 neutral	4
	2 (3000 µ+/part.)	8,6
	4 neutral	6,6
	10 neutral	10,2

(Data from CEA-IPSN, Paris - France)

Detection Limits:

	Alpha	Beta
Instrument background:	0.003 Bq/m ³	0.012 Bq/m ³
At 10 Bq/m ³ nat. Activity:	0.17 Bq/m ³	0.35 Bq/m ³

(MDC in accordance to DIN 25482 with a Measuring Time of 1 h and
 $k_{1-\alpha} = k_{1-\beta} = 1,645$)